

图形点阵液晶显示模块使用手册

XP12232E **LCD MODULE USER MANUAL**

1. FUNCTIONS & FEATURES

Features

- Dot Matrix: 122×32 Dots
- LCD Mode: STN
- Controller IC: SED1520 or Equivalent
- Driving Method: 1/32 Duty; 1/9 Bias
- Viewing Angle: 6 O'clock direction
- 6800 serial 8-Bit MPU Interface
- Backlight: LED
- Operating Temperature Range: -20 to 70°C;
- Storage Temperature Range : -30 to 80°C;

Note: Color tone is slightly changed by temperature and driving voltage.

2. MECHANICAL SPECIFICATIONS

ITEM	SPECIFICATIONS	UNIT
Module Size	87.0L×29.0W×13.0 (max) H	mm
View Area	68.0×18.0	mm
Effective Area	122×32	dots
Dot Size	0.35×0.40	mm

广州鑫平电子科技有限公司

Dot Pitch	0.40×0.45	mm
-----------	-----------	----

3. EXTERNAL DIMENSIONS

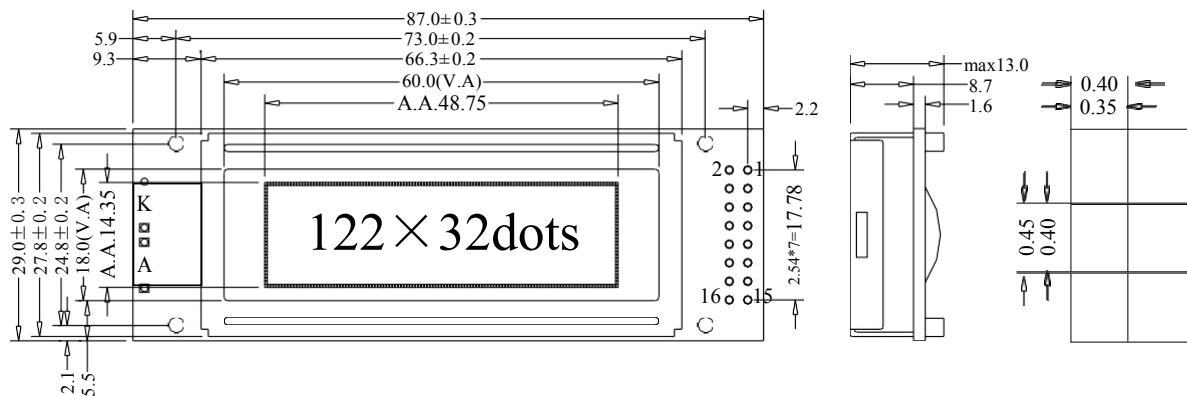

4. BLOCK DIAGRAM

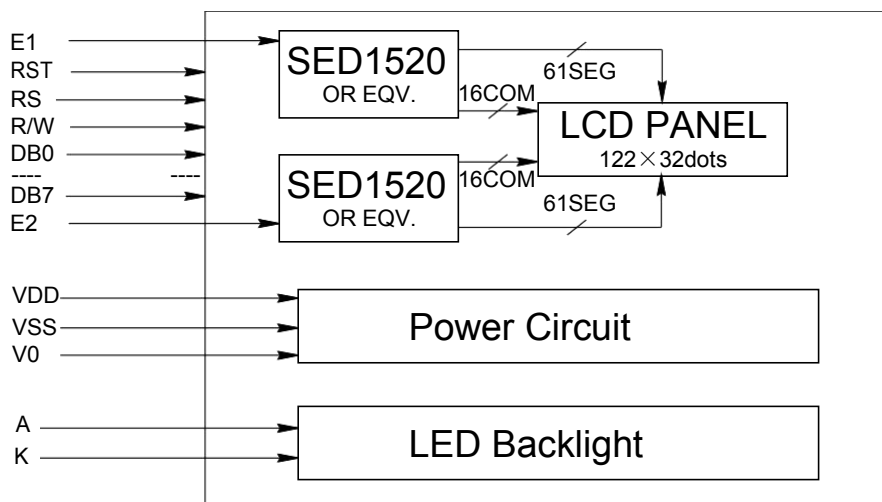

5. POWER SUPPLY

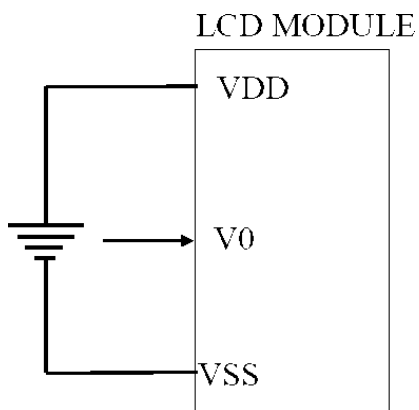

6. PIN DESCRIPTION

ITEM	SYMBOL	I/O	FUNCTION
1	VDD	5.0V	Power Supply For Logic
2	VSS	0V	Power Ground
3	V0	Input	Contrast Adjust
4	/RST	Input	Reset Signal

广州鑫平电子科技有限公司

5	E1	Input	Enable Signal A
6	E2	Input	Enable Signal B
7	R/W	Input	H: Read L: Write
8	RS	Input	H: DB0-DB7=Data L: DB0-DB7=Command
9 ~ 16	DB0 ~ DB7	I/O	Data Bus

7. MAXIMUM ABSOLUTE LIMIT (T=25°C)

Items	Symbol	Standard Value	Unit
Supply Voltage	Vdd	-0.3~7.0	V
Input Voltage	Vin	Vss~Vdd	V
Operating Temperature	Top	-20~70	°C
Storage Temperature	Tst	-30~80	°C

Note: Voltage greater than above may damage the module

All voltages are specified relative to Vss=0V

8. ELECTRICAL CHARACTERISTICS

8.1 DC Characteristics (VDD=+5V, VSS=0V, Ta=-0~+50° C)

Items	Symbol	Min	TYP	Max	Unit	Condition
Operating Voltage	Vdd	4.8	5.0	5.2	V	Vdd
Supply Current	Idd	—	5	10	mA	except LED backlight
Input High Voltage	Vin	Vdd-2.2	—	Vdd	V	RS,RW,E,DB0-DB7
Input Low Voltage	Vil	0	—	0.8	V	
Output High Voltage	Voh	Vdd-0.3	—	Vdd	V	Ioh=-0.1mA,DB0-DB7
Output Low Voltage	Vol	0	—	0.3	V	Iol=0.1mA,DB0-DB7
LCD Driving Voltage	Vlcd	4.7	4.8	5.0	V	Vdd-V0

8.2 AC Characteristics (VDD=+5V, VSS=0V, TTa=-20~75°)

Items	Symbol	Min	Max	Unit
Address set-up time with respect to R/W	t _{AS1}	20	—	nS
Address set-up time with respect to RS	t _{AS2}	20	—	nS
Address hold time with respect to R/W	t _{AH1}	10	—	nS
Address hold time with respect to RS	t _{AH2}	10	—	nS
Enable pulse falling/rising time	t _F ,t _R	—	15	nS

广州鑫平电子科技有限公司

System cycle time	t_{CYC}	1000	—	nS
Enable pulse width for READ	t_{EWR}	100	—	nS
Enable pulse width for WRITE	t_{EWW}	80	—	nS
Data setup time	t_{DS}	80	—	nS
Data hold time	t_{DH}	10	—	nS
Data access time	t_{ACC}	—	90	nS
Data output hold time	t_{OH}	10	60	nS

MPU write timing

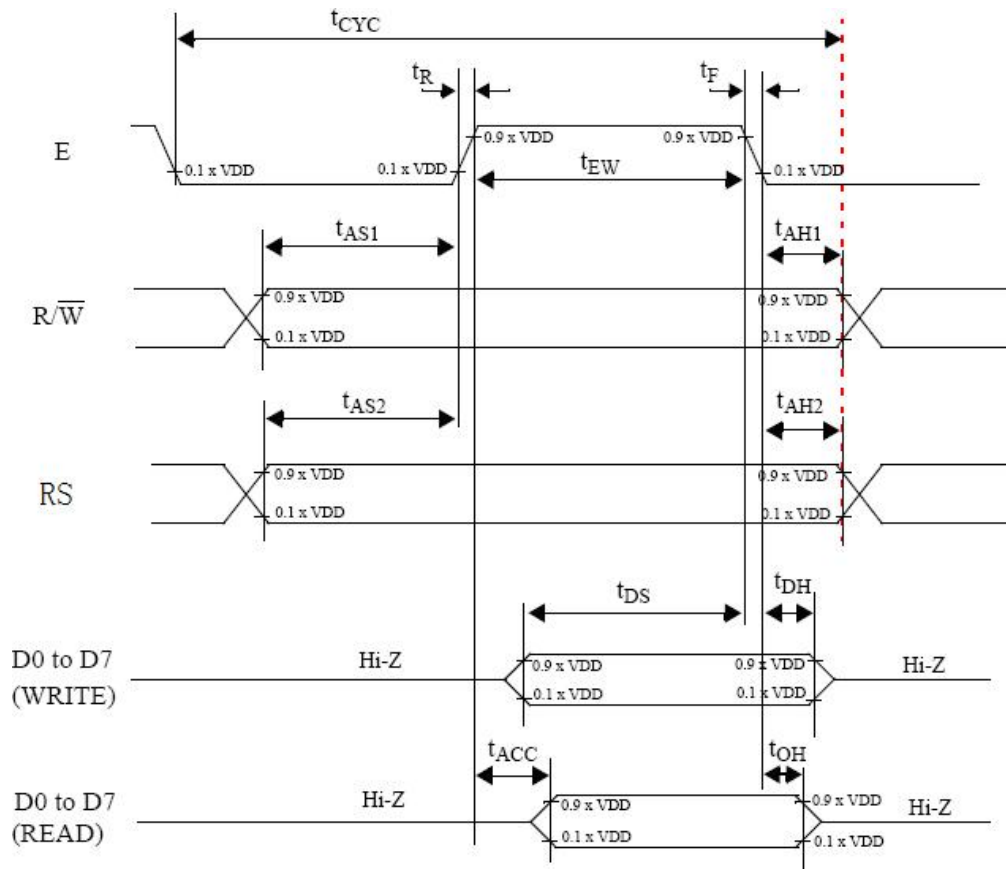

9. FUNCTION SPECIFICATIONS

9.1. Basic Setting

To drive the LCD module correctly and provide normally display, please use the following setting:

- Select duty=1/32;

广州鑫平电子科技有限公司

- ADC=1;
- Display start line=0;
- LCD display=ON;
- READ-MODIFY-WRITE=OFF.

Note:

- These setting/commands should issue to both controllers while start up;
- See the Display control instructions section for details.

9.2. Adjusting The LCD Display Contrast

A Variable-Resistor must be connected to the LCD module for providing a reference to V0. The recommended value of the Variable-Resistor is 20K to 50K.

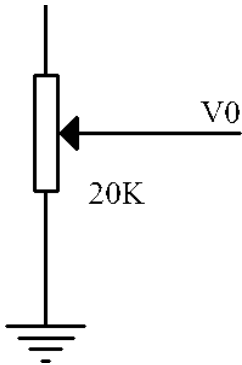

9.3. Resetting The LCD Module

The LCD module should be initialized by setting /RST terminal at low level when turning the power. Keep /RST terminal at high level, during power on. After the power supply is stable, a hardware reset signal should supply to the /RST terminal. The LCD module will be initialized at the rising and falling edge of /RST signal. For normal running, /RST signal must be kept at high level.

9.4. Display Memory Map

Page address	Data	LCD Display (font view)
2	DB7 DB0	

广州鑫平电子科技有限公司

3	DB7 DB0										
0	DB7 DB0										
1	DB7 DB0										
Column driver		Y1	Y2	...	Y60	Y61	Y1	Y2	...	Y60	Y61
Column address		14h—4Fh					14h—4Fh				
Total		61×32dots					61×32dots				
Drive(accessed by)		E1					E2				

Note:

- Display start line=0;
- ADC=0.

9.5. Display Control Instructions

广州鑫平电子科技有限公司

Instructions	Code										Function	Note	
	R/W	A0	DB7	DB6	DB5	DB4	DB3	DB2	DB1	DB0			
Display ON/OFF	0	0	1	0	1	0	1	1	1	0/1	0 = OFF 1 = ON (Display Data RAM is not affected)	*1	
Set Display Start Line	0	0	1	1	0	Display Start Line (0 ~31)					Specifies RAM line corresponding to the top line of display	*1	
Set Page Address	0	0	1	0	1	1	1	0	Page (0 ~ 3)		Set Page Address Register	*1	
Set Column Address	0	0	0	Column Address (0 ~ 79)							Set Column Address Counter	*1	
Read Status	1	0	Busy	ADC	ON/OFF	Reset	0	0	0	0	Busy=1, Busy Busy=0, Ready ADC=1, CW output ADC=0, CCW output ON/OFF=1, Display off ON/OFF=0, Display on Reset=1, Being reset Reset=0, Normal	*3	
Write Display Data	0	1	Display Data									Write Display Data to display data RAM	*1
Read Display Data	1	1	Display Data									Read Display Data from display data RAM	*3
Select ADC	0	0	1	0	1	0	0	0	0	0/1	0 = CW output 1 = CCW output	*1	
Static Drive ON/OFF	0	0	1	0	1	0	0	1	0	0/1	0 = normal drive 1 = static drive	*1	
Select duty	0	0	1	0	1	0	1	0	0	0/1	0 = 1/16 duty 1 = 1/32 duty	*1	
Read-Modify-Write	0	0	1	1	1	0	0	0	0	0	Read-modify-write = ON	*1	
End	0	0	1	1	1	0	1	1	1	0	Read-modify-write = OFF	*1	
Reset	0	0	1	1	1	0	0	0	1	0	Software Reset	*1	

Note:

1*. Only one section(driver) could be read at the same time.

2*. For the details of the display control instructions, please refer to SBN1661G datasheet.

10.DESIGN AND HANDING PRECAUTION

- 10.1. The LCD panel is made by glass. Any mechanical shock (eg. Dropping form high place) will damage the LCD module. Do not add excessive force on the surface of the display, which may cause the Display color change abnormally.
- 10.2. The polarizer on the LCD is easily get scratched. If possible, do not remove the LCD protective film until the last step of installation.
- 10.3. Never attempt to disassemble or rework the LCD module.
- 10.4. Only Clean the LCD with Isopropyl Alcohol or Ethyl Alcohol. Other solvents (eg. water) may damage the LCD.
- 10.5. When mounting the LCD module, make sure that it is free form twisting, warping and distortion.

广州鑫平电子科技有限公司

- 10.6. Ensure to provide enough space(with cushion) between case and LCD panel to prevent external force adding on it, or it may cause damage to the LCD or degrade the display result
- 10.7. Only hold the LCD module by its side. Never hold LCD module by add force on the heat seal or TAB.
- 10.8. Never add force to component of the LCD module. It may cause invisible damage or degrade of the reliability.
- 10.9. LCD module could be easily damaged by static electricity. Be careful to maintain an optimum anti-static work environment to protect the LCD module.
- 10.10. When peeling of the protective film form LCD, static charge may cause abnormal display pattern. It is normal and will resume to normal in a short while.
- 10.11. Take care and prevent get hurt by the LCD panel edge.
- 10.12. Never operate the LCD module exceed the absolute maximum ratings.
- 10.13. Keep the signal line as short as possible to prevent noisy signal applying to LCD module.
- 10.14. Never apply signal to the LCD module without power supply.
- 10.15. IC chip (eg. TAB or COG) is sensitive to the light. Strong lighting environment could possibly cause malfunction. Light sealing structure casing is recommend.
- 10.16. LCD module reliability may be reduced by temperature shock.
- 10.17. When storing the LCD module, avoid exposure to the direct sunlight, high humidity, high temperature or low temperature. They may damage or degrade the LCD module