

图形点阵液晶显示模块使用手册

XP12832A **LCD MODULE USER MANUAL**

1. FUNCTIONS & FEATURES

Features

- Dot Matrix: 128×32 Dots
- LCD Mode: STN
- Controller IC: KS0107 or Equivalent
- Driving Method: 1/32 Duty; 1/6 Bias
- Viewing Angle: 6 O'clock direction
- 6800 serial 8-Bit MPU Interface
- Backlight: LED
- Operating Temperature Range: -20 to 70°C;
- Storage Temperature Range : -30 to 80°C;

Note: Color tone is slightly changed by temperature and driving voltage.

广州鑫平电子科技有限公司

2. MECHANICAL SPECIFICATIONS

ITEM	SPECIFICATIONS	UNIT
Module Size	110.0L×65.0W×14.5 (max) H	mm
View Area	76.0×25.0	mm
Effective Area	128×32	dots
Dot Size	0.52×0.52	mm
Dot Pitch	0.57×0.57	mm

3. EXTERNAL DIMENSIONS

广州鑫平电子科技有限公司

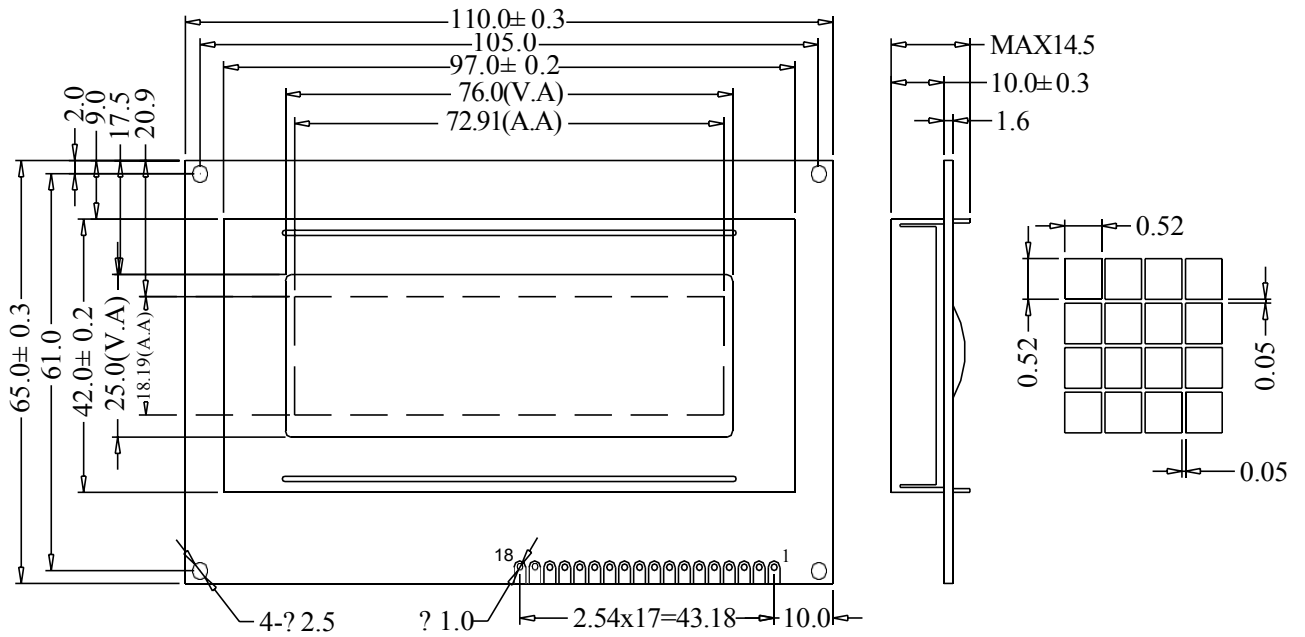

4. BLOCK DIAGRAM

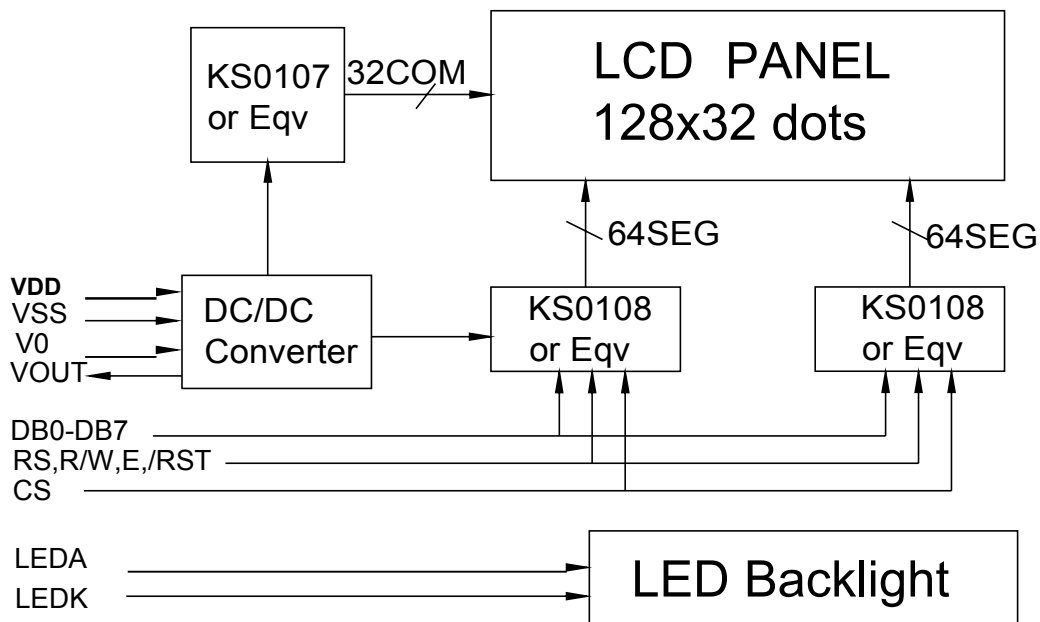

5. POWER SUPPLY

广州鑫平电子科技有限公司

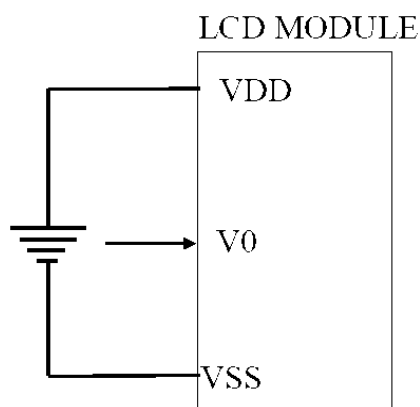

6. PIN DESCRIPTION

ITEM	SYMBOL	LEVEL	FUNCTION
1	LEDK	0V	Power Supply For LED Backlight
2	LEDA	5.0V	
3	VEE	—	Contrast Adjust
4	VDD	5.0V	Power Supply For Logic
5	VSS	0V	Power Ground
6	E	H, H->L	Enable Signal
7	D/I	H/L	H: Data L: Command
8	R/W	H/L	H: Read L: Write
9	/CS	H/L	Chip Selection
10	/RST	L	Reset Signal
11	DB0	H/L	Data Bus
~	~		
18	DB7		

7. MAXIMUM ABSOLUTE LIMIT (T=25°C)

Items	Symbol	Standard Value	Unit
Supply Voltage	Vdd	-0.3~7.0	V
Input Voltage	Vin	Vss~Vdd	V
Operating Temperature	Top	-20~70	°C
Storage Temperature	Tst	-30~80	°C

Note: Voltage greater than above may damage the module

广州鑫平电子科技有限公司

All voltages are specified relative to $V_{SS}=0V$

8. ELECTRICAL CHARACTERISTICS

8.1 DC Characteristics ($V_{DD}=+5V$, $V_{SS}=0V$, $T_a=-0\sim+50^\circ C$)

Items	Symbol	Min	TYP	Max	Unit	Condition
Operating Voltage	Vdd	4.8	5.0	5.2	V	Vdd
Supply Current	Idd	—	8	15	mA	except LED backlight
Input High Voltage	Vin	2.0	—	Vdd	V	RS,RW,E,DB0-DB7
Input Low Voltage	Vil	0	—	0.8	V	
Output High Voltage	Voh	2.4	—	—	V	Ioh=-0.1mA,DB0-DB7
Output Low Voltage	Vol	—	—	0.4	V	Iol=0.1mA,DB0-DB7
LCD Driving Voltage	Vlcd	4.8	5.0	5.2	V	Vdd-V0

8.2 AC Characteristics ($V_{DD}=+5V$, $V_{SS}=0V$, $T_a=-20\sim75^\circ$)

Items	Symbol	Min	TYP	Max	Unit
E cycle time	t_C	1000	—	—	nS
E high level width	t_{WH}	450	—	—	nS
E low level width	t_{WL}	450	—	—	nS
E rise time	t_R	—	—	25	nS
E fall time	t_F	—	—	25	nS
Address set-up time	t_{ASU}	140	—	—	nS
Address hold time	t_{AH}	10	—	—	nS
Data set-up time	t_{DSU}	200	—	—	nS
Data delay time	t_D	—	—	320	nS
Data hold time (write)	t_{DHW}	10	—	—	nS
Data hold time (read)	t_{DHR}	20	—	—	nS

MPU write timing

广州鑫平电子科技有限公司

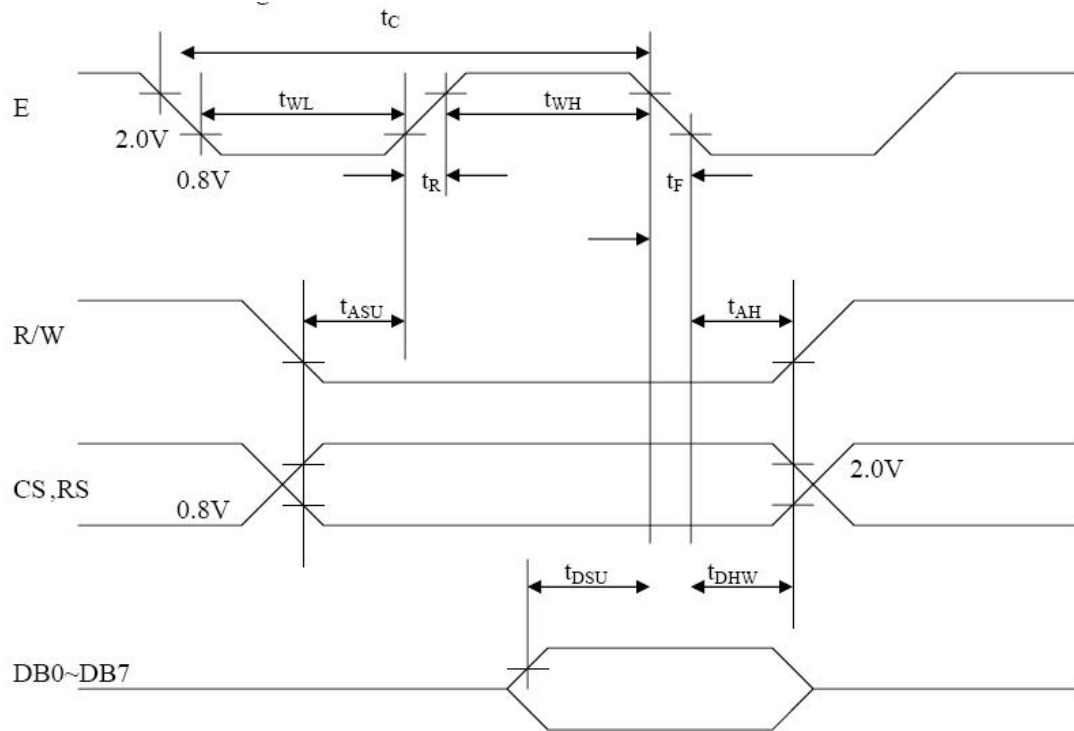

MPU read timing

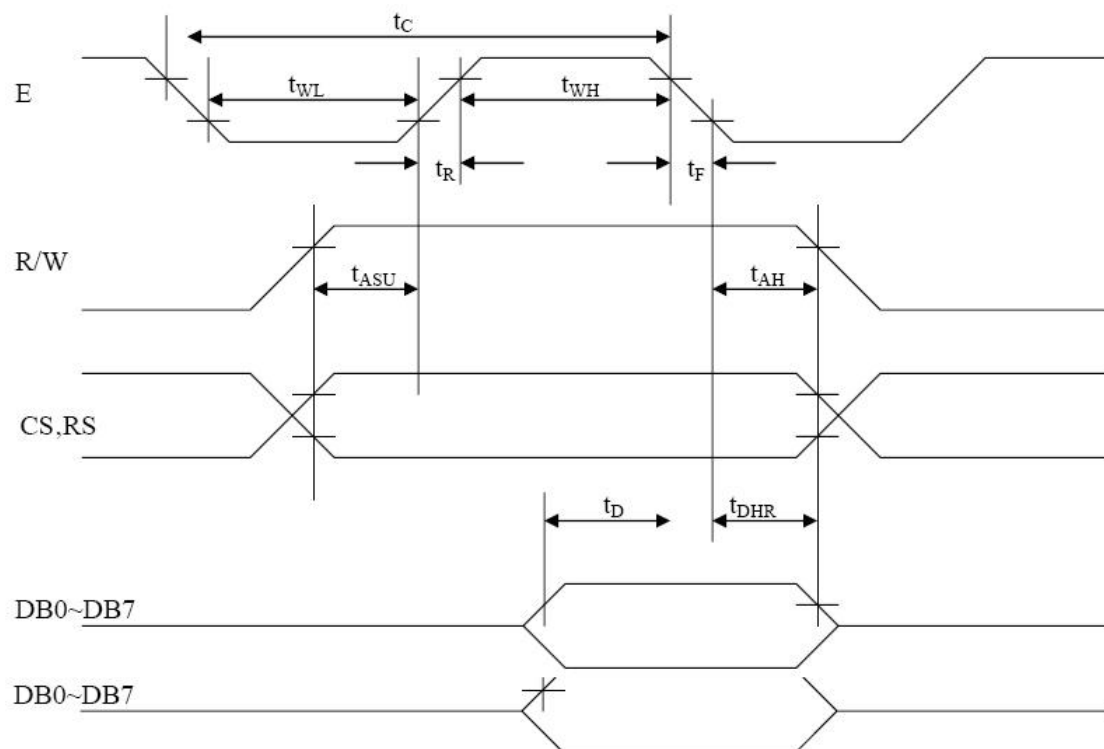

广州鑫平电子科技有限公司

9. FUNCTION SPECIFICATIONS

9.1. Basic Setting

To drive the LCD module correctly and provide normally display, please use the following setting:

- Display start line(Z address)=0;
- LCD display=ON.

Note:

- These setting/commands should issue to both controllers while start up;
- See the Display control instructions section for details.

9.2. Adjusting The LCD Display Contrast

A Variable-Resistor must be connected to the LCD module for providing a reference to V0. The recommended value of the Variable-Resistor is 20K to 50K.

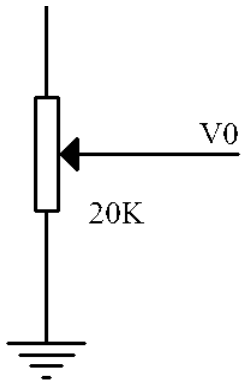

9.3. Resetting The LCD Module

The LCD module should be initialized by setting /RST terminal at low level when turning the power. When /RST pull low, the LCD module will:

广州鑫平电子科技有限公司

- Display on
- Display start line register becomes 0.(Z-address=0)

While /RST is low, no instructions can be accepted except status read. Therefore execute other instructions after making sure that DB4=0(clear /RST) and DB7=0(ready) by status read instruction, the condition of power supply at initial power up are as follow:

Items	Symbol	Min	TYP	Max	Unit
Reset time	t_{rs}	2.0	—	—	uS
Rise time	t_r	—	—	150	nS

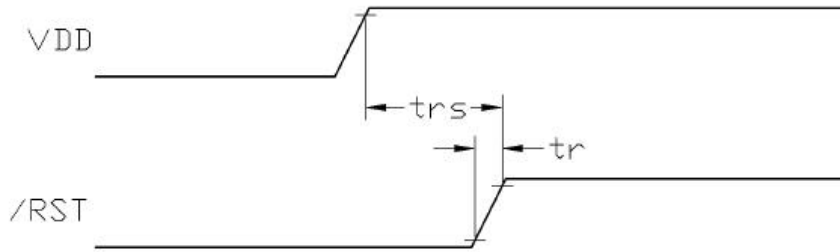

9.4. Display Memory Map

Page (X) address	Data	LCD Display (font view)									
0	DB7 DB0										
1	DB7 DB0										
2	DB7 DB0										
3	DB7 DB0										
Column driver		Y1	Y2	...	Y63	Y4	Y1	Y2	...	Y63	Y4
Column (Y) address		00h—3Fh					00h—3Fh				
Total		64×64dots					64×64dots				
Chip select		CS =0					CS =1				

Note:

- Display start line (Z address)=0;
- The display data store separated in two divers;
- The display data for the left section could be accessed by setting CS=0,
The display data for the right section could be accessed by setting CS=1.

广州鑫平电子科技有限公司

9.5. Internal registers

There are three registers in each section of LCD module. Each of them could be controlled independently.

9.5.1. Page (X)Address Register

X address register designates pages of internal display data RAM. Count function is not available. The address should be set by instruction.

9.5.2. Column (Y)Address Register

Y address register designates address of internal display data RAM. It could be set by instruction and it increased by 1 automatically by read or write display data operations.

9.5.3. Display Start line (Z) Register

Y address register indicates of display data RAM to LCD top line. It may be used for scrolling the display pattern on the LCD.

9.6. Display Control Instructions

广州鑫平电子科技有限公司

Instructions	Code										Function	Note
	RS	R/W	DB7	DB6	DB5	DB4	DB3	DB2	DB1	DB0		
Display on/off	0	0	0	0	1	1	1	1	1	1/0	Controls the display on or off. Internal status and display data in RAM is not affected 0=off, 1=on	*2
Set Column (Y) Address	0	0	0	1	Y address (0-63)						Set the Column address into the Y address counter	*2
Set Page (X) Address	0	0	1	0	1	1	1	X address (0-7)			Set the Page address into the X address register	*2
Set Display Start Line (Z address)	0	0	1	1	Z address (0-63)						Indicates the display data RAM displayed at the top of the screen	*2
Status Read	0	1	Busy	0	on/off	Reset	0	0	0	0	Read status Busy=L, Driver ready; Busy=H, Driver busy on/off=L, Display is on; on/off=H, Display is off Reset=L, Normal Running; Reset=H, reset	*1
Write Display Data	1	0	Write data								Write display data into display data RAM, After writing instruction, Y address counter increased by 1 automatically	*2
Read Display Data	1	1	Read data								Read display data form the display data RAM	*1

Note:

1*. Only one section(driver) could be read at the same time.

2*. For the details of the display control instructions, please refer to KS0108B datasheet.

10.DESIGN AND HANDING PRECAUTION

- 10.1. The LCD panel is made by glass. Any mechanical shock (eg. Dropping form high place) will damage the LCD module. Do not add excessive force on the surface of the display, which may cause the Display color change abnormally.
- 10.2. The polarizer on the LCD is easily get scratched. If possible, do not remove the LCD protective film until the last step of installation.
- 10.3. Never attempt to disassemble or rework the LCD module.
- 10.4. Only Clean the LCD with Isopropyl Alcohol or Ethyl Alcohol. Other solvents (eg. water) may damage the LCD.
- 10.5. When mounting the LCD module, make sure that it is free form twisting, warping and distortion.
- 10.6. Ensure to provide enough space(with cushion) between case and LCD panel to prevent external force adding on it, or it may cause damage to the LCD or degrade the display result
- 10.7. Only hold the LCD module by its side. Never hold LCD module by add force on the heat seal or TAB.
- 10.8. Never add force to component of the LCD module. It may cause invisible damage or degrade of the reliability.
- 10.9. LCD module could be easily damaged by static electricity. Be careful to maintain an optimum anti-static work environment to protect the LCD module.
- 10.10. When peeling of the protective film form LCD, static charge may cause abnormal display pattern. It is normal and will resume to normal in a short while.
- 10.11. Take care and prevent get hurt by the LCD panel edge.

广州鑫平电子科技有限公司

- 10.12. Never operate the LCD module exceed the absolute maximum ratings.
- 10.13. Keep the signal line as short as possible to prevent noisy signal applying to LCD module.
- 10.14. Never apply signal to the LCD module without power supply.
- 10.15. IC chip (eg. TAB or COG) is sensitive to the light. Strong lighting environment could possibly cause malfunction. Light sealing structure casing is recommend.
- 10.16. LCD module reliability may be reduced by temperature shock.
- 10.17. When storing the LCD module, avoid exposure to the direct sunlight, high humidity, high temperature or low temperature. They may damage or degrade the LCD module