

## 中文字库液晶显示模块使用手册

### **XP12832ZB** **LCD MODULE USER MANUAL**

#### **1. FUNCTIONS & FEATURES**

##### Features

- Dot Matrix: 128×32 Dots
- LCD Mode: STN
- Controller IC: ST7920or Equivalent
- Driving Method: 1/32 Duty; 1/5 Bias
- Viewing Angie: 6 O'clock direction
- 6800 family 8-Bit/4-Bit or serial MPU Interface
- Backlight: LED
- Operating Temperature Range: -20 to 70℃;
- Storage Temperature Range : -30 to 80℃;

Note: Color tone is slightly changed by temperature and driving voltage.

## 2. MECHANICAL SPECIFICATIONS

ITEM	SPECIFICATIONS	UNIT
Module Size	84.0L×44.0W×13.0 (max) H	mm
View Area	70.0×20.0	mm
Effective Area	128×32	dots
Dot Size	0.48×0.48	mm
Dot Pitch	0.52×0.52	mm

## 3. EXTERNAL DIMENSIONS

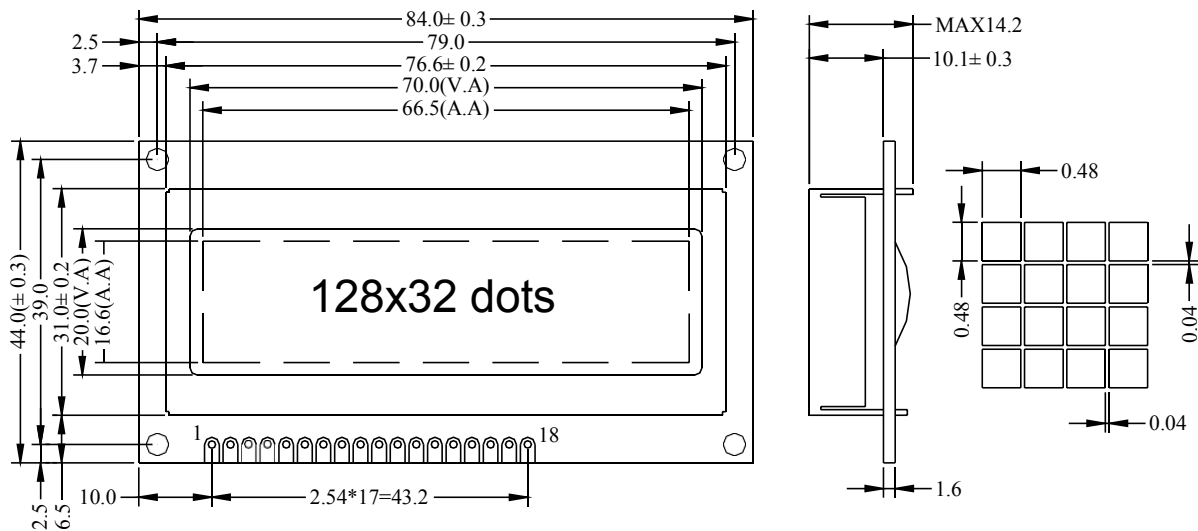

## 4. BLOCK DIAGRAM

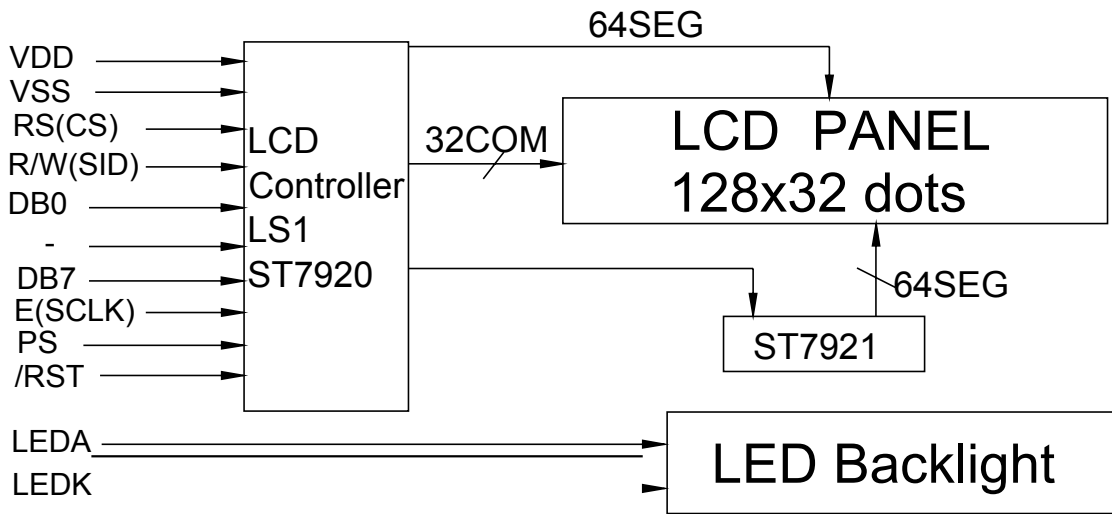

## 5. POWER SUPPLY

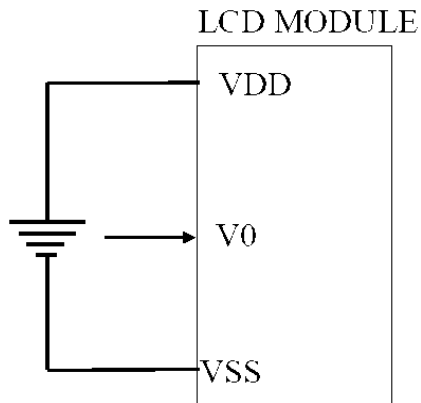

# 广州鑫平电子科技有限公司

## 6. PIN DESCRIPTION

ITEM	SYMBOL	LEVEL	FUNCTION	
1	VSS	0V	Power Ground	
2	VDD	5.0V	Power Supply For Logic	
3	V0/NC	—	Contrast Adjust	
4	RS(CS)	H/L	H: Data L: Command	Chip selection signal H: enable the data transfer L: reset the serial data counter
5	R/W(SID)	H/L	H: Read L: Write	Serial data input
6	E(SCLK)	H, H->L	Enable Signal	Serial clock input
7 ~ 14	DB0 ~ DB7	H/L	Data Bus	Keep open when choosing serial bus MPU interface
15	PSB	H/L	H: parallel interface L: serial interface	
16	/RST	L	Reset signal	
17	LEDA	0V	Power Supply For LED Backlight	
18	LEDK	5.0V		

Note: In serial mode, the CS is used for resetting the serial data shifting counter, It could not disable the data shifting into the LCD module.

## 7. MAXIMUM ABSOLUTE LIMIT (T=25°C)

Items	Symbol	Standard Value	Unit
Supply Voltage	Vdd	-0.3~7.0	V
Input Voltage	Vin	Vss~Vdd	V
Operating Temperature	Top	-20~70	°C
Storage Temperature	Tst	-30~80	°C

Note: Voltage greater than above may damage the module  
All voltages are specified relative to Vss=0V

## 8. ELECTRICAL CHARACTERISTICS

### 8.1 DC Characteristics (VDD=5V, Ta=25°C)

Items	Symbol	Min	TYP	Max	Unit	Condition
-------	--------	-----	-----	-----	------	-----------

# 广州鑫平电子科技有限公司

Operating Voltage	Vdd	4.8	5.0	5.2	V	Vdd
Supply Current	Idd	—	8	15	mA	except LED backlight
Input High Voltage	Vin	Vdd-1	—	Vdd	V	RS,RW,E,DB0-DB7
Input Low Voltage	Vil	0	—	0.6	V	
Output High Voltage	Voh	Vdd-1	—	Vdd	V	Ioh=-0.1mA,DB0-DB7
Output Low Voltage	Vol	0	—	0.5	V	Iol=0.1mA,DB0-DB7
LCD Driving Voltage	Vlcd	4.8	5.0	5.2	V	Vdd-V0

## 8.2a AC Characteristics (VDD=5V, Ta=25°C) Parallel Mode Interface

Items	Symbol	Test Condition	Min	TYP	Max	Unit
Enable cycle time	t <sub>PW</sub>	Pin E	1500	—	—	nS
Enable pulse width	t <sub>C</sub>	Pin E	175	—	—	nS
Enable rise/fall time	t <sub>R</sub> ,t <sub>F</sub>	Pin E	—	—	250	nS
Address set-up time	t <sub>AS</sub>	Pin: RS,R/W,E	13	—	—	nS
Address hold time	t <sub>AH</sub>	Pin: RS,R/W,E	25	—	—	nS
Data set-up time	t <sub>DSW</sub>	Pin: DB0-DB7	50	—	—	nS
Data hold time	t <sub>H</sub>	Pin: DB0-DB7	25	—	—	nS
Data delay time (read)	t <sub>DDR</sub>	Pin: DB0-DB7	—	—	125	nS

## 8.2b AC Characteristics (VDD=5V, Ta=25°C) Serial Mode Interface

Items	Symbol	Test Condition	Min	TYP	Max	Unit
Serial clock cycle	t <sub>SCYC</sub>	Pin RS(SCLK)	600	—	—	nS
SCLK high pulse width	t <sub>SHW</sub>	Pin RS(SCLK)	300	—	—	nS
SCLK low pulse width	t <sub>SLW</sub>	Pin RS(SCLK)	300	—	—	nS
SCLK rise/fall time	t <sub>R</sub> ,t <sub>F</sub>	Pin RS(SCLK)	—	—	20	nS
SID data set-up time	t <sub>SDS</sub>	Pin R/W(SID)	40			nS
SID data hold time	t <sub>SDH</sub>	Pin R/W(SID)	40			nS
CS set-up time	t <sub>CSS</sub>	Pin CS	60			nS
CS hold time	t <sub>CSH</sub>	Pin CS	60	—	—	nS

MPU write timing

# 广州鑫平电子科技有限公司

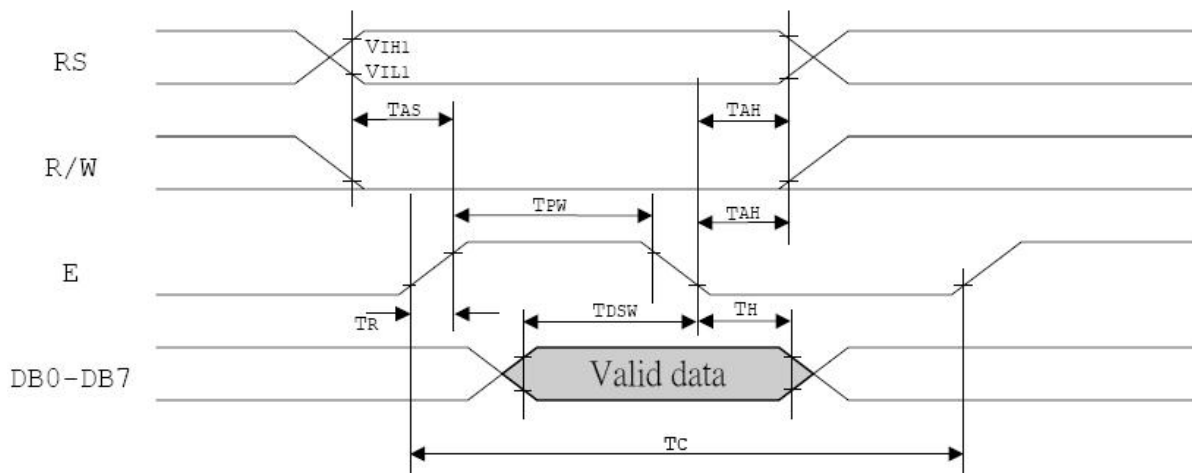

## MPU read timing

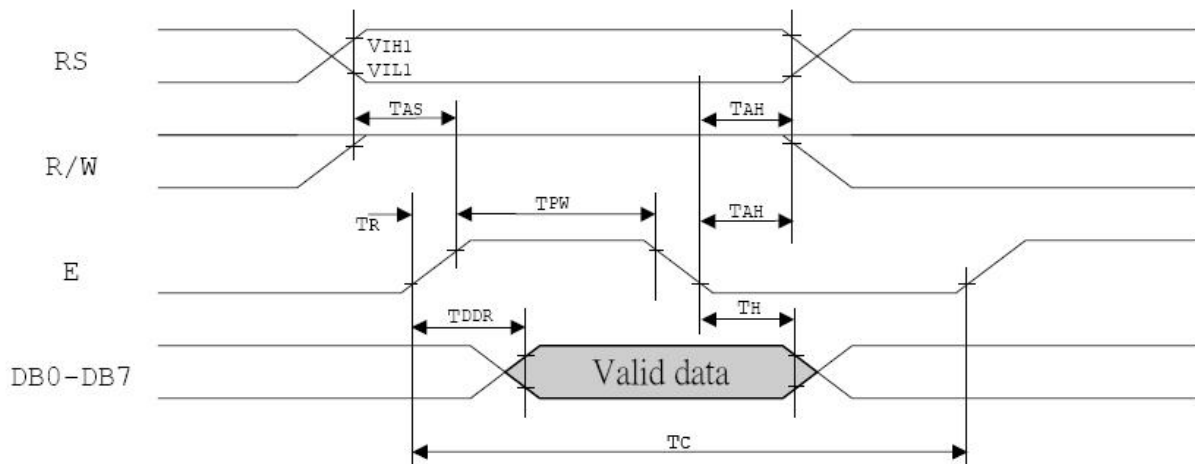

## MPU read timing

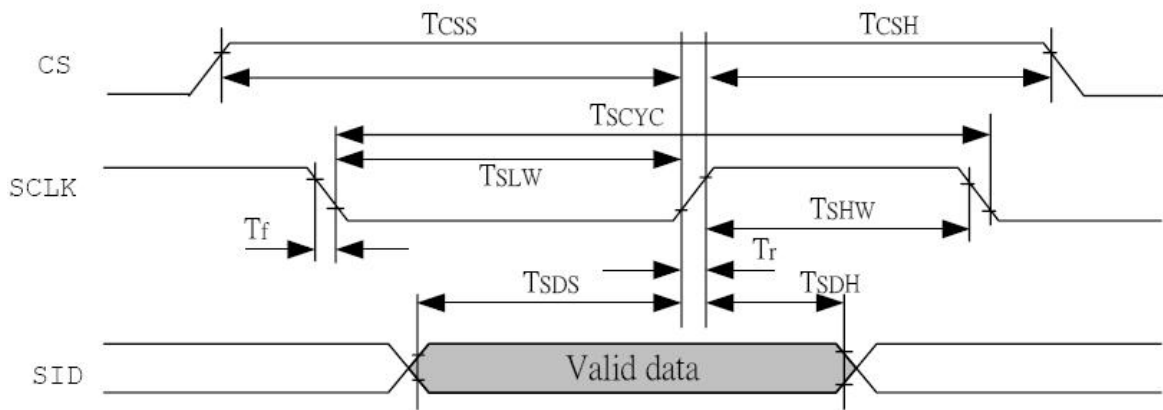

## 9. FUNCTION SPECIFICATIONS

### 9.1. Resetting The LCD Module

The LCD module should be initialized by setting /RST terminal at low level when turning the power on. See the reset timing section for detail.

Items	Symbol	Min	TYP	Max	Unit
Reset pulse width	$t_{rw}$	2.0	—	—	$\mu S$
Reset start time	$t_{res}$	—	—	100	nS

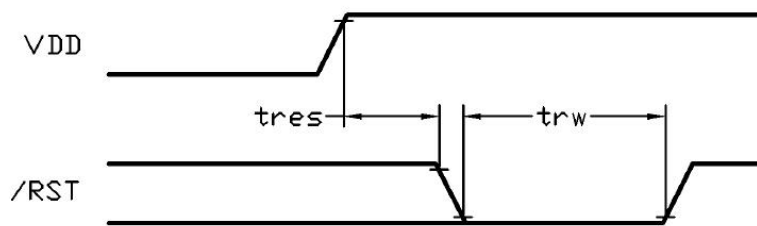

**Rest Timing Diagram**

The initialized status is as follow:

Function	Initialized Status
Enter Mode Set	<b>I/D=1</b> cursor move to right <b>S=0</b> DDRAM address counter
Display status	<b>D=0</b> display=OFF <b>C=0</b> cursor=OFF <b>B=0</b> cursor position blink=OFF

# 广州鑫平电子科技有限公司

Function Set	DL=1 8-bit interface RE=0 Basic Instruction Set
Scroll Or RAM Address select	SR=0 CGRAM address access is enable
Reverse	R1=1,R0=0 First line normal
Extended Function Set	G=0 Graphic display OFF

## 9.2. Using Parallel Interface

When PSB=H, the LCD module is in parallel interface mode. 8-bit or 4-bit bus interface could be selected by FUNCTION SET instruction DL bit.

In 4-bit bus interface, every 8-bit instruction/data is separated into two parts. First, transfer the higher 4-bit(D7-D4), then transfer the lower 4-bit(D3-D0). They are transferred via DB7-DB4 terminals, where DB3-DB0 are not in used (leave open or pull high).

## 9.3. Using Serial Interface

When PSB=L, the LCD module is in serial interface mode (write only). In this mode, CS pin should be used. CS=H, enable the data transfer. CS=L, reset the serial data counter, terminate the data transition and clear the data buffer. As the controller IC has no instruction buffer area, it must wait for the previous instruction to finish before sending the next one. Thus transferring multiple instruction/data, execution time must be considered. Starting a transmission, a start byte is required. It consists 5 consecutive "1" follow with a "0", as RS bit (register select bit) and a "0". Then the 8-bit instruction/data should be separated into 2 groups. First group is DB7-DB4, followed by 4 consecutive "0". The second group is DB3-DB0 with 4 consecutive "0". See the follow data sequence diagram for detail:

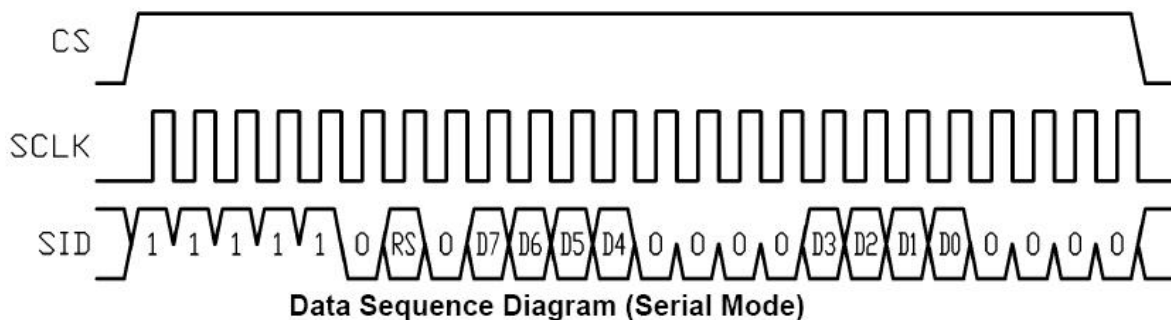

## 9.4. Display Memory Map

There are 3 main memory-areas in the LCD module for display.

- Character Generator RAM (CGRAM);
- Graphic Display RAM (GDRAM);
- Display Data RAM (DDRAM).



# 广州鑫平电子科技有限公司

## 9.4.1 Character Generator RAM (CGRAM)

Character Generator RAM is for storing the User-defined characters (a 16×16 dots font). There are only 4 characters could be defined. The User-defined character codes are 0000h, 0002h, 0004h and 0006h. They could be called into DDRAM as normal character.

User-defined Character Code	CGRAM Address	CGRAM data	
		D15 ~ D8	D7 ~ D0
0000h	00h : 0Fh	16 x 16 dot font	
0002h	10h : 1Fh	16 x 16 dot font	
0004h	20h : 2Fh	16 x 16 dot font	
0006h	30h : 3Fh	16 x 16 dot font	

**CGRAM Address Map**

## 9.4.2 Graphic Display RAM (GDRAM)

GDRAM is for full graphics display. It could be displayed when G=1(set by Extended Function Set in Extended instruction Set ).

		Horizontal Address (X)				
		00h	01h	~	06h	07h
		D15 ~ D0	D15 ~ D0	~	D15 ~ D0	D15 ~ D0
Vertical Address (Y)	00h	<b>128 X 32 pixel</b>				
	01h					
	⋮					
	⋮					
	⋮					
	⋮					
1Eh						
1Fh						

**GDRAM Address Map**

Note:

- The mapping is based on Vertical Scroll Displacement Address=0;

# 广州鑫平电子科技有限公司

- Another  $128 \times 32$  Graphics display RAM space is not showed. They could be displayed adjusting the Vertical Scroll Displacement Address value.

## 9.4.3 Display Data RAM (DDRAM)

GB character code (16-bit, A1A0h-F7FFh) could write into DDRAM for displaying the simplified Chinese character ( $16 \times 16$  dots font). User characters defined by user that stored in CGRAM could also be used. The display character should be on grid only.

		DDRAM Address (Lower 4bit)													
		00h		01h		02h		~		05h		06h		07h	
		H	L	H	L	H	L	~		H	L	H	L	H	L
DDRAM Address (Upper 4bit)	80h	8 x 2 Characters (16x16 dots font)													
	90h														

**DDRAM Address Map with 16x16 dots font**

Note:

- The mapping is based on Vertical Scroll Displacement Address=0;
- Another  $8 \times 2$ (characters) Display Data RAM space is not showed. They could be displayed adjusting the Vertical Scroll Displacement Address value.

Standard ASCII code (00h-7fh) could write into DDRAM for displaying the standard ASCII character ( $8 \times 16$  dots font). The display character should be on grid only, and 2 characters should be written in each write operation.

		DDRAM Address (Lower 4bit)													
		00h		01h		02h		~		05h		06h		07h	
		H	L	H	L	H	L	~		H	L	H	L	H	L
DDRAM Address (Upper 4bit)	80h	8 x 2 Characters (8x16 dots font)													
	90h														

**DDRAM Address Map with 8x16 dots font**

Note:

- The mapping is based on Vertical Scroll Displacement Address=0;
- Another  $16 \times 2$ (characters) Display Data RAM space is not showed. They could be displayed adjusting the Vertical Scroll Displacement Address value.

# 广州鑫平电子科技有限公司

## 9.5. Display Control Instructions

### Basic Instruction Set

RE=0, basic instruction set

Instructions	Code										Function	
	RS	R/W	DB7	DB6	DB5	DB4	DB3	DB2	DB1	DB0		
CLEAR	0	0	0	0	0	0	0	0	0	1	Fill DDRAM with "20h", and set DDRAM address counter (AC) to "00h"	
HOME	0	0	0	0	0	0	0	0	0	1	X	Set DDRAM address counter (AC) to "00h" and put cursor to origin. DDRAM content no changed.
ENTRY MODE	0	0	0	0	0	0	0	0	1	I/D	S	Set cursor position and display shift when doing write or read operation I/D=1, cursor move right AC increased by 1 I/D=0, cursor move left, AC decreased by 1 S=1, toggle the shift of the entire display (based on I/D defined direction)
DISPLAY ON/OFF	0	0	0	0	0	0	1	D	C		B	D=1, display ON D=0, display OFF C=1, cursor ON C=0, cursor OFF B=1, blink ON B=0, blink OFF
CURSOR DISPLAY CONTROL	0	0	0	0	0	1	S/C	R/L	X	X	X	Cursor position and display shift control. DDRAM content no changed.
FUNCTION SET	0	0	0	0	1	DL	X	RE	X	X	X	DL=1, 8bit interface DL=0, 4bit interface RE=1, extended instruction RE=0; basic instruction
SET CGRAM ADDR	0	0	0	1	AC5	AC4	AC3	AC2	AC1	AC0		Set CGRAM address to address counter (AC) Make sure that in extended instruction SR=0 (scroll or RAM address selected)
SET DDRAM ADDR	0	0	AC7	AC6	AC5	AC4	AC3	AC2	AC1	AC0		Set DDRAM address to address counter (AC), where AC7 =1, AC6=0
READ BF & ADDR	0	1	BF	AC6	AC5	AC4	AC3	AC2	AC1	AC0		Read busy flag (BF) for completion of the internal operation, also read out the value of AC
WRITE RAM	1	0	D7	D6	D5	D4	D3	D2	D1	D0		Write data to internal RAM (DDRAM, CGRAM,GDRAM) For 16bit data, write two byte consecutively, high byte first, then low byte
READ RAM	1	1	D7	D6	D5	D4	D3	D2	D1	D0		Read data from internal RAM (DDRAM, CGRAM,GDRAM)

Note:

- For the details of the display control instructions, please refer to ST7920 datasheet;
- RE is the selection byte of basic and extended instruction set. Each time altering the value of RE, it will remain. Thus, it is not necessary to set RE every time when using the same

# 广州鑫平电子科技有限公司

group of instruction set.

## Extended Instruction Set

RE=1, extended instruction set

Instructions	Code											Function
	RS	RW	DB7	DB6	DB5	DB4	DB3	DB2	DB1	DB0		
SCROLL or RAM ADDR SELECT	0	0	0	0	0	0	0	0	0	1	SR	SR=1, enable vertical scroll position SR=0, enable CGRAM address (basic instruction)
REVERSE	0	0	0	0	0	0	0	0	1	R1	R0	Toggle 1 out of 4 line (in DDRAM) of the display to be reversed (initial value is R1 ,R0 = 0, 0
EXTENDED FUNCTION SET	0	0	0	0	1	DL	X	RE	G		0	DL=1, 8bit interface DL=0, 4bit interface RE=1, extended instruction RE=0; basic instruction G=1, graphics display ON G=0, graphics display OFF
SET SCROLL ADDR	0	0	0	1	AC5	AC4	AC3	AC2	AC1	AC0		Set the address of vertical scroll Make sure extended instruction SR=1, enable vertical scroll position.
SET GRAPHICS RAM ADDR	0	0	1	AC6	AC5	AC4	AC3	AC2	AC1	AC0		Set the GDRAM address to address counter (AC) Dual byte command should write consecutively First byte set the Vertical address AC6~AC0 Second byte set the Horizontal address AC3~AC0
	0	0	1	0	0	0	AC3	AC2	AC1	AC0		

Note:

- For the details of the display control instructions, please refer to ST7920 datasheet;
- RE is the selection byte of basic and extended instruction set. Each time altering the value of RE, it will remain. Thus, it is not necessary to set RE every time when using the same group of instruction set.

## 10. DESIGN AND HANDLING PRECAUTION

- 10.1. The LCD panel is made by glass. Any mechanical shock (eg. Dropping from high place) will damage the LCD module. Do not add excessive force on the surface of the display, which may cause the Display color change abnormally.
- 10.2. The polarizer on the LCD is easily get scratched. If possible, do not remove the LCD protective film until the last step of installation.
- 10.3. Never attempt to disassemble or rework the LCD module.
- 10.4. Only Clean the LCD with Isopropyl Alcohol or Ethyl Alcohol. Other solvents (eg. water) may damage the LCD.

# 广州鑫平电子科技有限公司

---

- 10.5. When mounting the LCD module, make sure that it is free from twisting, warping and distortion.
- 10.6. Ensure to provide enough space(with cushion) between case and LCD panel to prevent external force adding on it, or it may cause damage to the LCD or degrade the display result
- 10.7. Only hold the LCD module by its side. Never hold LCD module by add force on the heat seal or TAB.
- 10.8. Never add force to component of the LCD module. It may cause invisible damage or degrade of the reliability.
- 10.9. LCD module could be easily damaged by static electricity. Be careful to maintain an optimum anti-static work environment to protect the LCD module.
- 10.10. When peeling of the protective film from LCD, static charge may cause abnormal display pattern. It is normal and will resume to normal in a short while.
- 10.11. Take care and prevent get hurt by the LCD panel edge.
- 10.12. Never operate the LCD module exceed the absolute maximum ratings.
- 10.13. Keep the signal line as short as possible to prevent noisy signal applying to LCD module.
- 10.14. Never apply signal to the LCD module without power supply.
- 10.15. IC chip (eg. TAB or COG) is sensitive to the light. Strong lighting environment could possibly cause malfunction. Light sealing structure casing is recommend.
- 10.16. LCD module reliability may be reduced by temperature shock.
- 10.17. When storing the LCD module, avoid exposure to the direct sunlight, high humidity, high temperature or low temperature. They may damage or degrade the LCD module