

## 图形点阵液晶显示模块使用手册

### **XP12864G** **LCD MODULE USER MANUAL**

#### **1. FUNCTIONS & FEATURES**

##### Features

- Dot Matrix: 128×64 Dots
- LCD Mode: STN
- Controller IC: KS0107 or Equivalent
- Driving Method: 1/64 Duty; 1/9 Bias
- Viewing Angle: 6 O'clock direction
- 6800 serial 8-Bit MPU Interface
- Backlight: LED
- Operating Temperature Range: -20 to 70°C;

# 广州鑫平电子科技有限公司

---

— Storage Temperature Range : -30 to 80°C;

Note: Color tone is slightly changed by temperature and driving voltage.

## 2. MECHANICAL SPECIFICATIONS

| ITEM           | SPECIFICATIONS            | UNIT |
|----------------|---------------------------|------|
| Module Size    | 107.0L×85.0W×14.0 (max) H | mm   |
| View Area      | 88.0×60.0                 | mm   |
| Effective Area | 128×64                    | dots |
| Dot Size       | 0.60×0.80                 | mm   |
| Dot Pitch      | 0.65×0.85                 | mm   |

## 3. EXTERNAL DIMENSIONS

# 广州鑫平电子科技有限公司

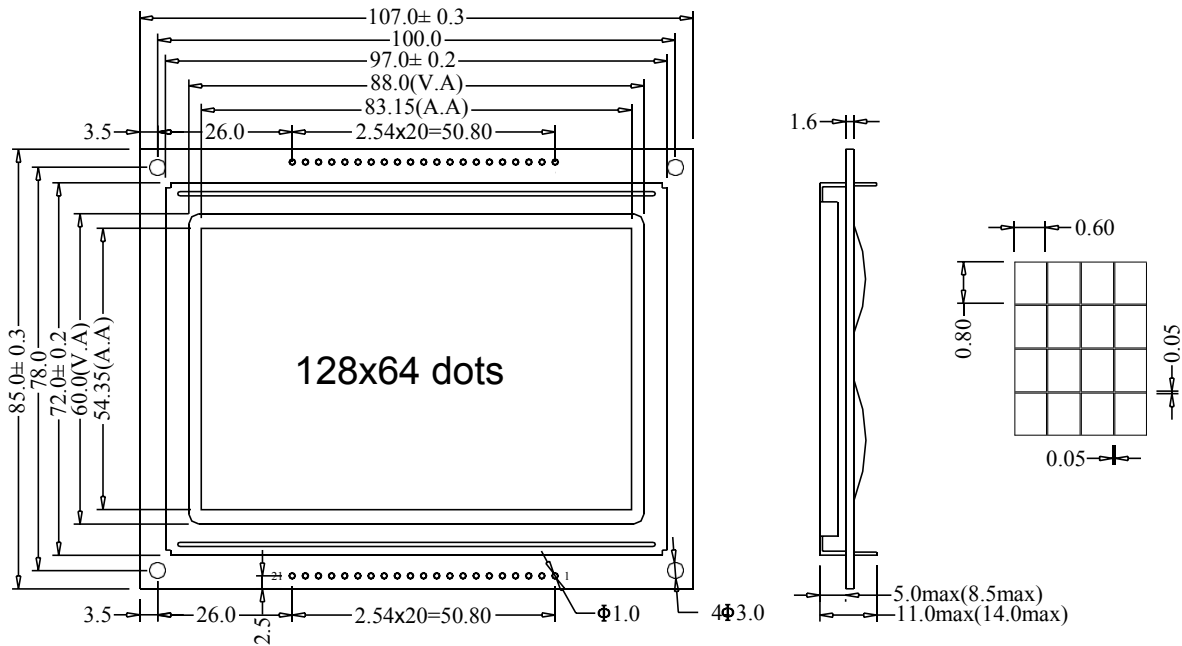

## 4. BLOCK DIAGRAM

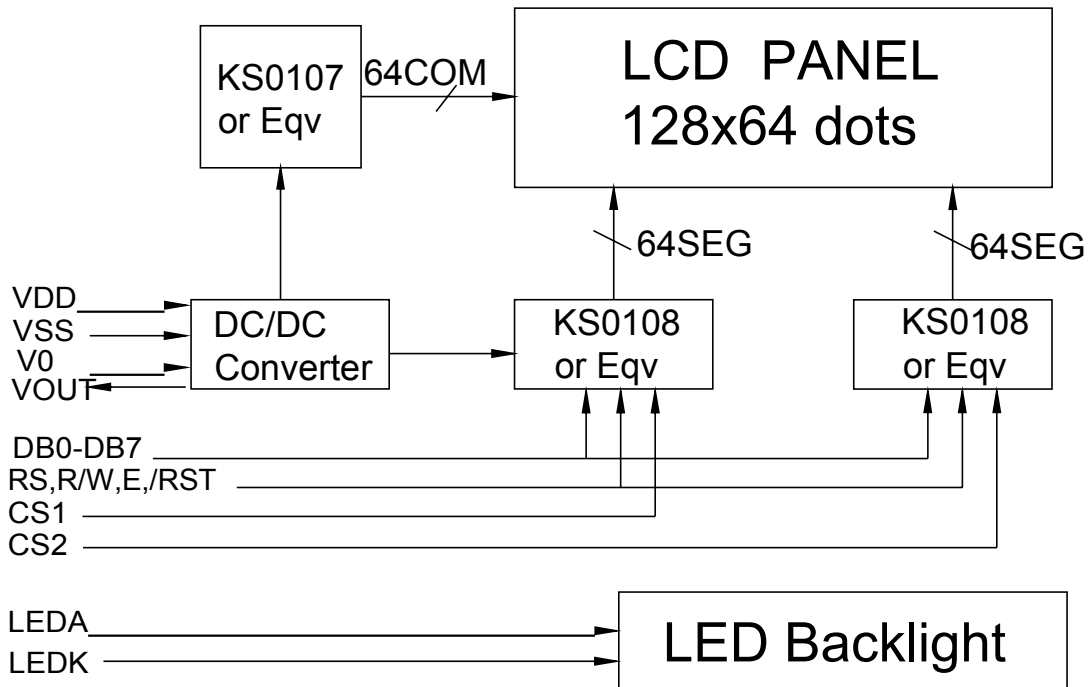

# 广州鑫平电子科技有限公司

## 5. POWER SUPPLY

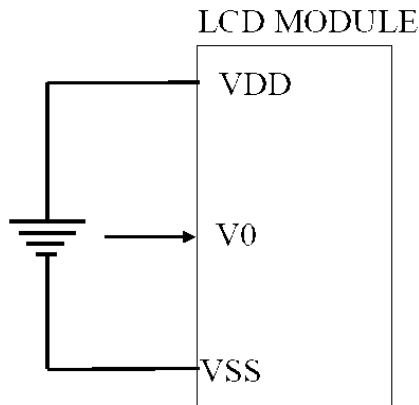

## 6. PIN DESCRIPTION

| ITEM         | SYMBOL          | LEVEL   | FUNCTION                                  |                                 |
|--------------|-----------------|---------|---|---------------------------------|
| 1            | VDD             | 5.0V    | Power Supply For Logic                    |                                 |
| 2            | VSS             | 0V      | Power Ground                              |                                 |
| 3            | V0              | —       | Contrast Adjust                           |                                 |
| 4            | RS              | H/L     | H: Data L: Command                        |                                 |
| 5            | R/W             | H/L     | H: Read L: Write                          |                                 |
| 6            | E               | H, H->L | Enable Signal                             |                                 |
| 7<br>~<br>14 | DB0<br>~<br>DB7 | H/L     | Data Bus                                  |                                 |
| 15           | CS1             | L       | Chip Selection A                          |                                 |
| 16           | CS2             | L       | Chip Selection B                          |                                 |
| 17           | /RST            | L       | Reset Signal                              |                                 |
| 18           | Vout            | —       | Negative Power output For LCD Driving     |                                 |
| 19           | ON/OFF          | H/L     | H: EL backlight on<br>L: EL backlight off | When LED backlight are not used |
| 20           | LEDA            | 5.0V    | Power Supply For LED Backlight            | When EL backlight are not used  |
| 21           | LEDK            | 0V      |   |                                 |

## 7. MAXIMUM ABSOLUTE LIMIT (T=25°C)

# 广州鑫平电子科技有限公司

| Items                 | Symbol | Standard Value | Unit |
|-----------------------|--------|----------------|------|
| Supply Voltage        | Vdd    | -0.3~7.0       | V    |
| Input Voltage         | Vin    | Vss~Vdd        | V    |
| Operating Temperature | Top    | -20~70         | °C   |
| Storage Temperature   | Tst    | -30~80         | °C   |

Note: Voltage greater than above may damage the module  
All voltages are specified relative to Vss=0V

## 8. ELECTRICAL CHARACTERISTICS

### 8.1 DC Characteristics (VDD=+5V, VSS=0V, Ta=-0~+50° C)

| Items               | Symbol | Min | TYP  | Max  | Unit | Condition            |
|---------------------|--------|-----|------|------|------|----------------------|
| Operating Voltage   | Vdd    | 4.8 | 5.0  | 5.2  | V    | Vdd                  |
| Supply Current      | Idd    | —   | 8    | 15   | mA   | except LED backlight |
| Input High Voltage  | Vin    | 2.0 | —    | Vdd  | V    | RS,RW,E,DB0-DB7      |
| Input Low Voltage   | Vil    | 0   | —    | 0.8  | V    |                      |
| Output High Voltage | Voh    | 2.4 | —    | —    | V    | Ioh=-0.1mA,DB0-DB7   |
| Output Low Voltage  | Vol    | —   | —    | 0.4  | V    | Iol=0.1mA,DB0-DB7    |
| LCD Driving Voltage | Vlcd   | 9.7 | 10.0 | 10.3 | V    | Vdd-V0               |

### 8.2 AC Characteristics (VDD=+5V, VSS=0V, TTa=-20~75° )

| Items                  | Symbol           | Min  | TYP | Max | Unit |
|------------------------|------------------|------|-----|-----|------|
| E cycle time           | t <sub>C</sub>   | 1000 | —   | —   | nS   |
| E high level width     | t <sub>WH</sub>  | 450  | —   | —   | nS   |
| E low level width      | t <sub>WL</sub>  | 450  | —   | —   | nS   |
| E rise time            | t <sub>R</sub>   | —    | —   | 25  | nS   |
| E fall time            | t <sub>F</sub>   | —    | —   | 25  | nS   |
| Address set-up time    | t <sub>ASU</sub> | 140  | —   | —   | nS   |
| Address hold time      | t <sub>AH</sub>  | 10   | —   | —   | nS   |
| Data set-up time       | t <sub>DSU</sub> | 200  | —   | —   | nS   |
| Data delay time        | t <sub>D</sub>   | —    | —   | 320 | nS   |
| Data hold time (write) | t <sub>DHW</sub> | 10   | —   | —   | nS   |
| Data hold time (read)  | t <sub>DHR</sub> | 20   | —   | —   | nS   |

MPU write timing

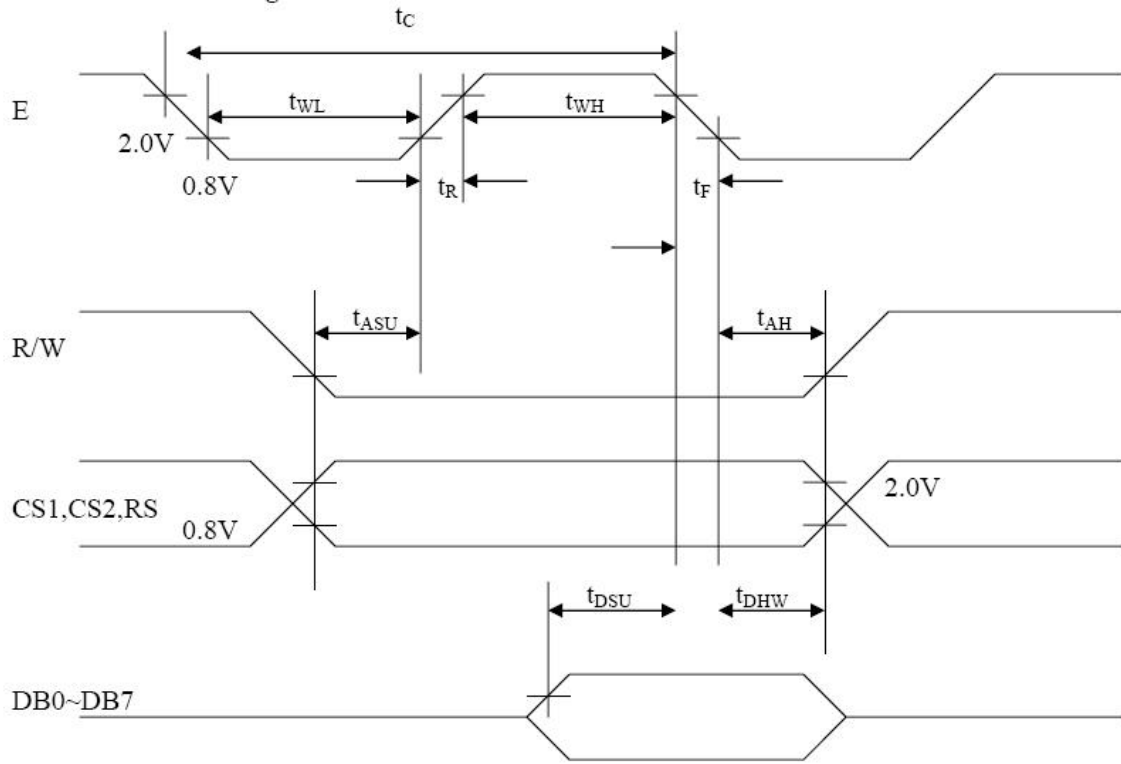

## MPU read timing

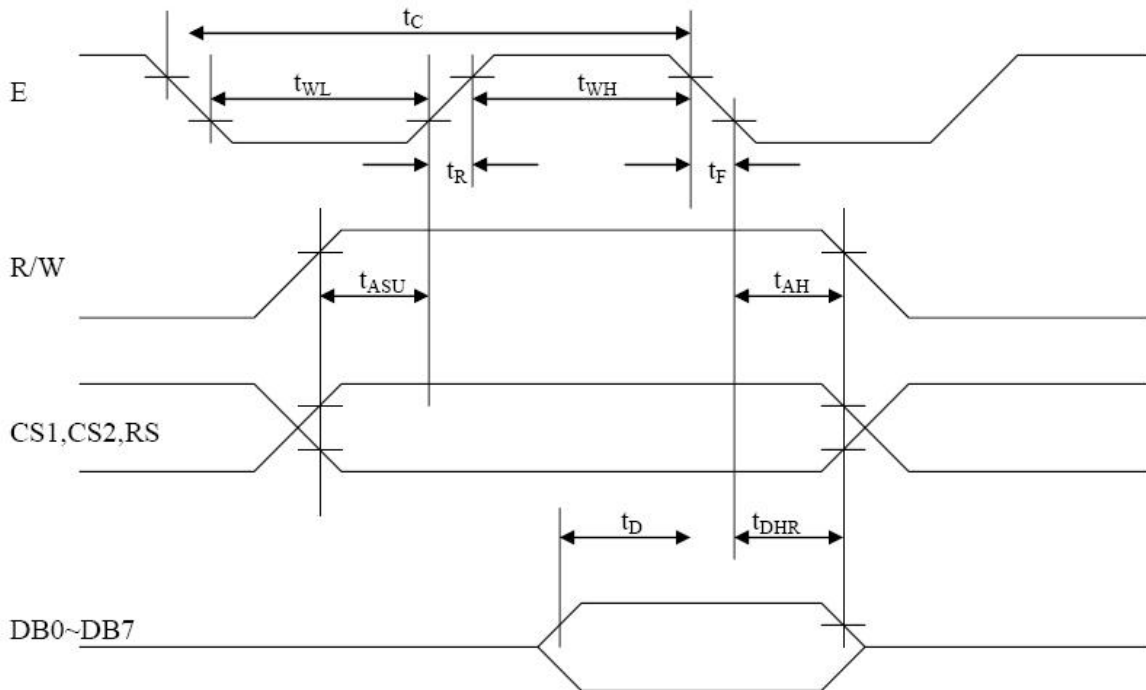

## 9. FUNCTION SPECIFICATIONS

# 广州鑫平电子科技有限公司

---

## 9.1. Basic Setting

To drive the LCD module correctly and provide normally display, please use the following setting:

- Display start line(Z address)=0;
- LCD display=ON.

Note:

- These setting/commands should issue to both controllers while start up;
- See the Display control instructions section for details.

## 9.2. Adjusting The LCD Display Contrast

A Variable-Resistor must be connected to the LCD module for providing a reference to V0. The recommended value of the Variable-Resistor is 20K to 50K.

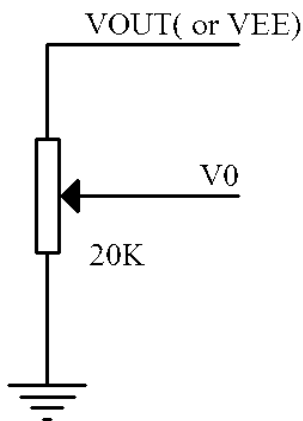

## 9.3. Resetting The LCD Module

The LCD module should be initialized by setting /RST terminal at low level when turning the power.

When /RST pull low, the LCD module will:

- Display on

# 广州鑫平电子科技有限公司

— Display start line register becomes 0.(Z-address=0)

While /RST is low, no instructions can be accepted except status read. Therefore execute other instructions after making sure that DB4=0(clear /RST) and DB7=0(ready) by status read instruction, the condition of power supply at initial power up are as follow:

| Items      | Symbol   | Min | TYP | Max | Unit |
|------------|----------|-----|-----|-----|------|
| Reset time | $t_{rs}$ | 2.0 | —   | —   | uS   |
| Rise time  | $t_r$    | —   | —   | 150 | nS   |

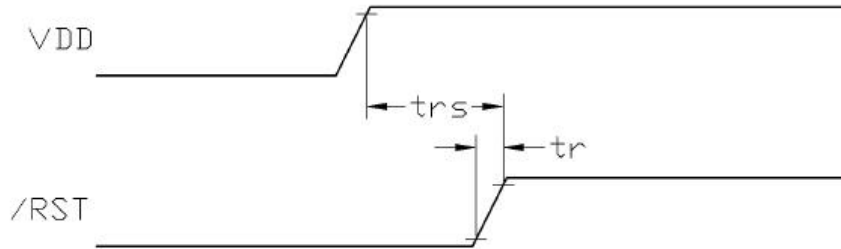

## 9.4. Display Memory Map

| Page (X) address   | Data            | LCD Display (font view) |     |     |     |     |             |     |     |     |     |
|--------------------|-----------------|-------------------------|-----|-----|-----|-----|-------------|-----|-----|-----|-----|
| 0                  | DB7<br> <br>DB0 |                         |     |     |     |     |             |     |     |     |     |
| 1                  | DB7<br> <br>DB0 |                         |     |     |     |     |             |     |     |     |     |
| ...                | ...             | ...                     | ... | ... | ... | ... | ...         | ... | ... | ... | ... |
| 6                  | DB7<br> <br>DB0 |                         |     |     |     |     |             |     |     |     |     |
| 7                  | DB7<br> <br>DB0 |                         |     |     |     |     |             |     |     |     |     |
| Column driver      |                 | Y1                      | Y2  | ... | Y63 | Y4  | Y1          | Y2  | ... | Y63 | Y4  |
| Column (Y) address |                 | 00h—3Fh                 |     |     |     |     | 00h—3Fh     |     |     |     |     |
| Total              |                 | 64×64dots               |     |     |     |     | 64×64dots   |     |     |     |     |
| Chip select        |                 | CS1=0,CS2=1             |     |     |     |     | CS1=1,CS2=0 |     |     |     |     |

Note:

- Display start line (Z address)=0;
- The display data store separated in two divers;
- The display data for the left section could be accessed by setting CS1=0,  
The display data for the right section could be accessed by setting CS2=0.



# 广州鑫平电子科技有限公司

## 9.5. Internal registers

There are three registers in each section of LCD module. Each of them could be controlled independently.

### 9.5.1. Page (X)Address Register

X address register designates pages of internal display data RAM. Count function is not available. The address should be set by instruction.

### 9.5.2. Column (Y)Address Register

Y address register designates address of internal display data RAM. It could be set by instruction and it increased by 1 automatically by read or write display data operations.

### 9.5.3. Display Start line (Z) Register

Y address register indicates of display data RAM to LCD top line. It may be used for scrolling the display pattern on the LCD.

## 9.6. Display Control Instructions

| Instructions                       | Code |     |            |     |                  |       |     |                 |     |     | Function   | Note  |    |
|------------------------------------|------|-----|------------|-----|------------------|-------|-----|-----------------|-----|-----|--|---|----|
|                                    | RS   | R/W | DB7        | DB6 | DB5              | DB4   | DB3 | DB2             | DB1 | DB0 |  |   |    |
| Display on/off                     | 0    | 0   | 0          | 0   | 1                | 1     | 1   | 1               | 1   | 1/0 | Controls the display on or off. Internal status and display data in RAM is not affected<br>0=off, 1=on   | *2  |    |
| Set Column (Y) Address             | 0    | 0   | 0          | 1   | Y address (0-63) |       |     |                 |     |     |  | Set the Column address into the Y address counter | *2 |
| Set Page (X) Address               | 0    | 0   | 1          | 0   | 1                | 1     | 1   | X address (0-7) |     |     | Set the Page address into the X address register   | *2  |    |
| Set Display Start Line (Z address) | 0    | 0   | 1          | 1   | Z address (0-63) |       |     |                 |     |     | Indicates the display data RAM displayed at the top of the screen  | *2  |    |
| Status Read                        | 0    | 1   | Busy       | 0   | on/off           | Reset | 0   | 0               | 0   | 0   | Read status<br>Busy=L, Driver ready; Busy=H, Driver busy<br>on/off=L, Display is on; on/off=H, Display is off<br>Reset=L, Normal Running; Reset=H, reset | *1  |    |
| Write Display Data                 | 1    | 0   | Write data |     |                  |       |     |                 |     |     | Write display data into display data RAM,<br>After writing instruction, Y address counter increased by 1 automatically                                   | *2  |    |
| Read Display Data                  | 1    | 1   | Read data  |     |                  |       |     |                 |     |     | Read display data form the display data RAM  | *1  |    |

Note:

1\*. Only one section(driver) could be read at the same time.

2\*. For the details of the display control instructions, please refer to KS0108B datasheet.

## 10.DESIGN AND HANDING PRECAUTION

# 广州鑫平电子科技有限公司

---

- 10.1. The LCD panel is made by glass. Any mechanical shock (eg. Dropping from high place) will damage the LCD module. Do not add excessive force on the surface of the display, which may cause the Display color change abnormally.
- 10.2. The polarizer on the LCD is easily get scratched. If possible, do not remove the LCD protective film until the last step of installation.
- 10.3. Never attempt to disassemble or rework the LCD module.
- 10.4. Only Clean the LCD with Isopropyl Alcohol or Ethyl Alcohol. Other solvents (eg. water) may damage the LCD.
- 10.5. When mounting the LCD module, make sure that it is free from twisting, warping and distortion.
- 10.6. Ensure to provide enough space(with cushion) between case and LCD panel to prevent external force adding on it, or it may cause damage to the LCD or degrade the display result
- 10.7. Only hold the LCD module by its side. Never hold LCD module by add force on the heat seal or TAB.
- 10.8. Never add force to component of the LCD module. It may cause invisible damage or degrade of the reliability.
- 10.9. LCD module could be easily damaged by static electricity. Be careful to maintain an optimum anti-static work environment to protect the LCD module.
- 10.10. When peeling of the protective film from LCD, static charge may cause abnormal display pattern. It is normal and will resume to normal in a short while.
- 10.11. Take care and prevent get hurt by the LCD panel edge.
- 10.12. Never operate the LCD module exceed the absolute maximum ratings.
- 10.13. Keep the signal line as short as possible to prevent noisy signal applying to LCD module.
- 10.14. Never apply signal to the LCD module without power supply.
- 10.15. IC chip (eg. TAB or COG) is sensitive to the light. Strong lighting environment could possibly cause malfunction. Light sealing structure casing is recommend.
- 10.16. LCD module reliability may be reduced by temperature shock.
- 10.17. When storing the LCD module, avoid exposure to the direct sunlight, high humidity, high temperature or low temperature. They may damage or degrade the LCD module